

PM1 motor data

MOTOR POWER†	45 - 250 Watts
TYPE	Permanent magnet DC brushed motor
SPEED*	1500 - 5000 rpm
VOLTAGE*	12V - 220V DC available range
CONNECTION*	Flying leads 30cm flexible
SHAFT*	Single or double ended on request
INERTIA	$2.60 \times 10^{-4} \text{kgm}^2$
WEIGHT	2.11 kg
RADIAL LOAD†	180 N
INSULATION CLASS	F
IP PROTECTION	Ventilated (IP21)
STARTING CURRENT	Approx 3 times full load current
ROTATION	Reversible two leads as standard
OPTIONS	See page 36



PM1 pictured with Parvalux standard flange

SPEED (Rpm)	MOTOR POWER (WATTS)			TORQUE (NM)			CURRENT (A)**			
	CONT	1 HOUR	15 MIN	CONT	1 HOUR	15 MIN	12V	24V	50V	
1500	45	55	75	0.3	0.4	0.5	0.8	0.5	0.18	No load current (A)
							6.6	2.3	1.38	Full load current (A)
2000	60	75	100	0.3	0.4	0.5	0.9	0.5	0.18	No load current (A)
							7.8	3.8	1.5	Full load current (A)
3000	90	110	150	0.3	0.4	0.5	1.3	0.8	0.4	No load current (A)
							11.9	5.3	2.5	Full load current (A)
4000	120	150	200	0.3	0.4	0.5	1.5	0.6	0.6	No load current (A)
							13	6.8	3	Full load current (A)
5000	150	180	250	0.3	0.3	0.5	**Please contact sales support for load currents			

PM1 • 3000 rpm • 24V • 90W

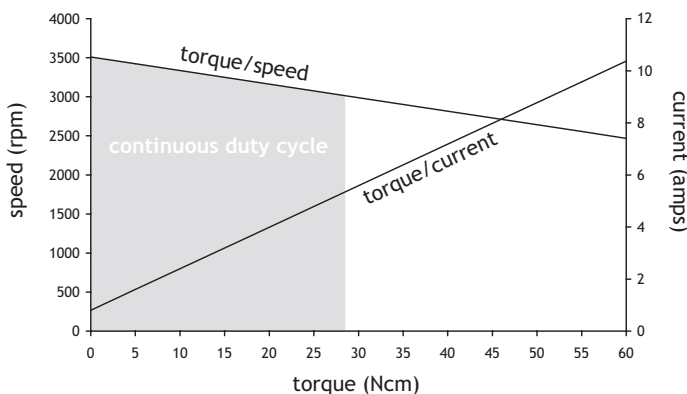

† Rated output power

* We produce all our motors in the UK and therefore voltage, speed, connection and shaft configuration can be customised to your exact requirements

† Based 10mm from motor mounting face with plain shaft extension

** Please contact our technical sales team for current ratings for alternative voltages and/or speeds

Motor construction

The motor frame comprises pressure die castings accurately located together ensuring a concentric air gap with correct bearing alignment. The armature laminations are pressed onto a precision steel shaft and are then statically and dynamically balanced. The armature is wound with first class quality synthetic covered copper wire manufactured to EN60085:2004 class "F" and then impregnated and baked in our automatic plant and accordingly can be considered to be tropically impregnated for all practical purposes.

Motor Enclosures

To IEC 34-5 and EN 60034: part 5 and IEC 34-6 and B.S. EN 60034-6. Please refer to the individual product pages to identify the corresponding ingress protection level (IP rating).

Bearings

We fit only first class shielded ball bearings into our motor and gearboxes which are spring loaded for quiet running. Typical operating temperatures range from -30°C to +120°C.

Brush gear

We provide an adjustable rocker type for maximum brush life and good commutation with easily accessible brushes. To achieve maximum brush life a form factor on the supply voltage as near to 1 as possible would be required.

Temperature

The PM1 is built with Class "F" insulation to EN60085:2004 which allows a temperature rise of 115°C based on an ambient of 40°C. These figures are with the motor running in normal working conditions in free air and not in any form of enclosure. Caution: Under full load the heat of the motor casing will be such that it is NOT possible to physically handle for any length of time.

Parvalux standard flange/mount

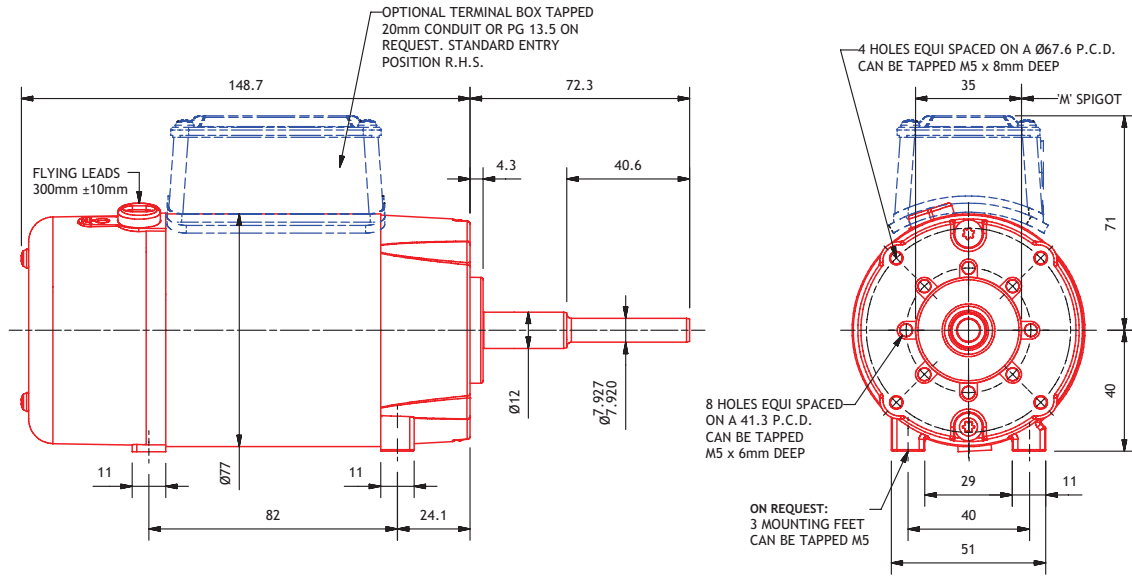

IEC Eurostandard flange/mount

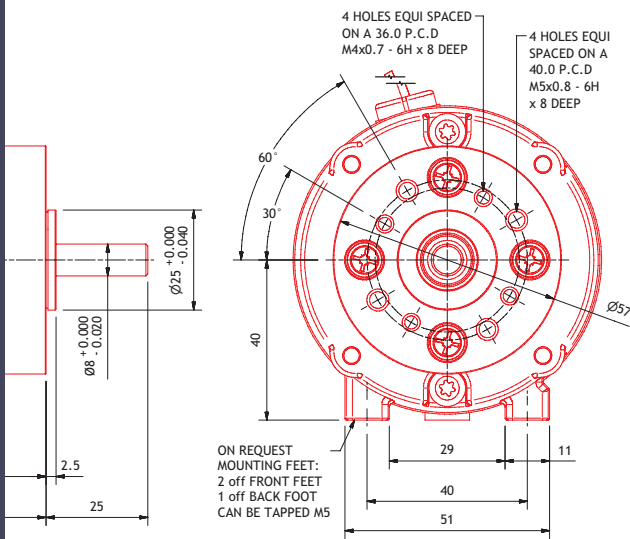

IEC B14 M56 flange/mount

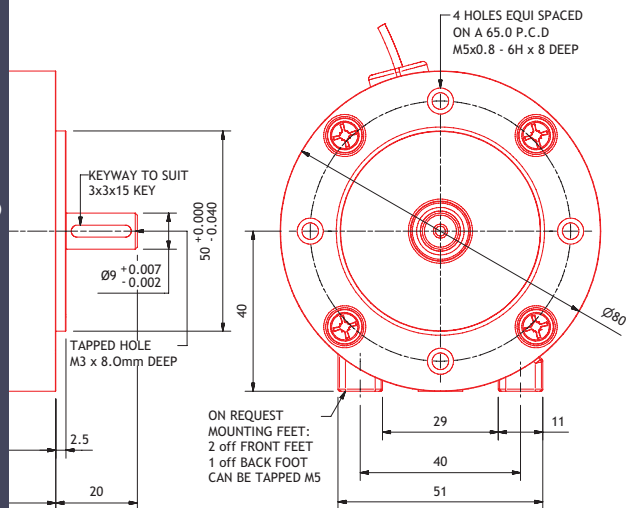

IEC B14 M63 flange/mount

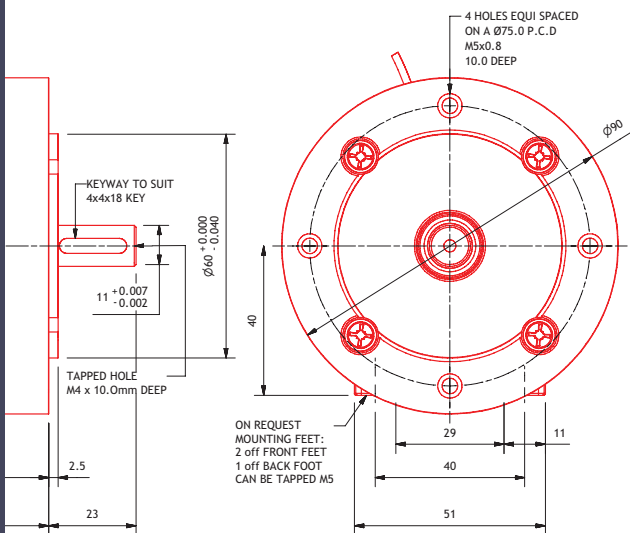

NEMA standard flange/mount

